

1	2	3	4	5	6	7	8	9	10	11	12	13	14	15	16	17
---	---	---	---	---	---	---	---	---	----	----	----	----	----	----	----	----

A
B
C
D
E
F
G
H

THE TOP SIDE OF THIS SCHEMATIC IS A TYPICAL WIRING OF THESE SWITCHES INTO A CONVENTIONAL MACHINE. THIS DIAGRAM IS FOR INFORMATIONAL PURPOSES ONLY. YOUR EQUIPMENT AND CONNECTION MAY VARY.



WWW.FERNDALSAFETY.COM
1-855-326-1243

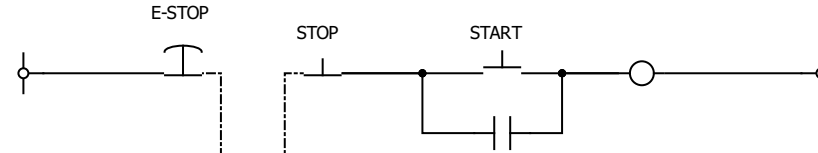

PEDAL MODEL FER-PED

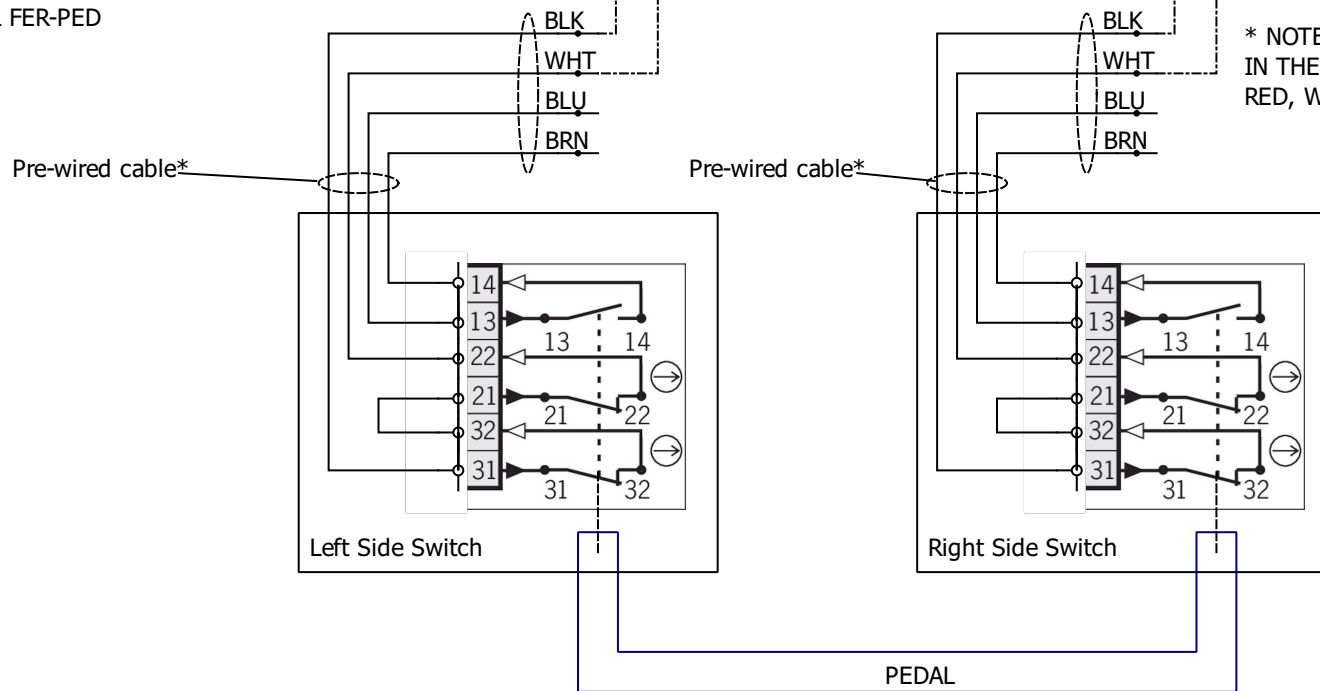

* NOTE: THESE ADDITIONAL WIRES INCLUDED IN THE PRE-WIRED CABLE ARE NOT USED: RED, WHITE/BLACK, GREEN

						PROJECT: Ferndale Stop Pedal Switch mod FER-PED			CLIENT:		
			Title: STOP PEDAL MODEL FER-PED			REV. B			Page: 1 of 1		
DESIGN John Spik			CHKD			DATE 10/5/2020			www.ferndalesafety.com		